

# Study of POST and PRE-Scheme of Dispersion Compensation in a 32 Channel DWDM Network with NRZ, RZ and Encoded Transmitter

Alok Singh, Abhishek Sureel

Department of Electronics and Communication Engineering, Delhi Technological University, Bawana Road, India

## Article Info

Article history:

Received 10 January 2021

Received in revised form

28 May 2021

Accepted 5 June 2021

Available online 15 June 2021

**Keywords:** Optisystem, Pre dispersion compensation, fibre Bragg grating, Post dispersion compensation.

**Abstract:** Dense Wavelength Division Multiplexing (DWDM) is a technique that has been developed to improve the channel range and bandwidth of optical fibre transmission systems. Multiple information channels of varying wavelengths are sent on a single fibre. The phenomenon of an input signal spreading out as it flows down the fibre is referred to as optical fibre dispersion. Chromatic, modal and polarisation mode dispersion are all examples of dispersion in fibre optic cable. To compensate for such dispersion, this paper introduces two techniques: Dispersion Compensation Fibre (DCF) and fibre Bragg Grating (FBG). In this paper we will explore Pre, Post Dispersion compensation technique with input as RZ, NRZ and MDRZ encoded. This analysis was carried out and simulated using Optisystem17, which took into account a number of variables such as Maximum Quality Factor, Eye Height, and Minimum Bit Error Rate (BER). Results were analysed for different lengths of transmission.

## 1. Introduction

The evolution of telecommunication sector, as well as the speed restriction for single wavelength, have contributed to a growth in the use of DWDM technologies. DWDM is based on multiplexing and simultaneously transferring multiple channels with different wavelengths over a single optical fiber communication channel. 200, 100, 50, and 25 gigahertz are typical channel spacings in DWDM. The following are the key elements of a simple DWDM system: DWDM terminal de-multiplexer, Intermediate line repeater, Intermediate optical terminal or optical add-drop multiplexer, DWDM terminal multiplexer. Following are advantage of DWDM: Increasing the capability of an optical network that already exists, Scalability, Dynamic provisioning, Transparency. Disadvantages of DWDM are crosstalk, Dispersion.

The phenomenon of an input spreading out as it flows down the fibre is referred to as optical fibre dispersion. Wavelength core diameter, Numerical aperture, laser line and refractive index width all contribute to the broadening of a light pulse as it travels through a fibre. With increase in length of optical fiber optical dispersion increases. Inter symbol Interference is the overall impact of dispersion on the output of an optical fiber communication system. There are many types of dispersion some of which are modal dispersion, chromatic dispersion and polarization mode dispersion. Modal dispersion is a form of disruption that occurs in waveguide and multimode fibre when the signal is stretched out in time due to the varying transmission speeds of all modes.

Light rays travel at a different speed in different medium which causes Chromatic dispersion.

Dispersion correction can be accomplished using a variety of techniques, including Optical filter, Dispersion Compensating Fibre (DCF), Electrical Dispersion Compensation, Optical Phase Conjugation, Digital Filters, Fibre Bragg Grating (FBG) and so on. [4] Each strategy has its own set of benefits and drawbacks. FBG and DCF are the most widely employed methods.

The term dispersion compensation is the process of cancelling the chromatic dispersion of an optical element. Interestingly, the term is also used in a broader context of dispersion regulation, which refers to the monitoring of a system's total chromatic dispersion.

In the 1980s, the concept of dispersion compensating fibre was proposed. It is an appropriate method for compensating dispersion because of robustness of DCF, since they are not easily influenced by wide bandwidth, temperature, and so (H.K. Dixit, 2012) on. The dispersion coefficient of DCF is a large negative value. Which in turn will act as an advantage in compensating fiber whose dispersion coefficient is positive.

**Corresponding Author,**

**E-mail address:** abhishek15153838@gmail.com

**All rights reserved:** <http://www.ijari.org>

For DCF length calculation by the formula:

$$L_{SMF} \times D_{SMF} = - (L_{DCF} \times D_{DCF}) \quad (1)$$

The three separate dispersion compensation systems based on the DCF setting: Pre, Post and Symmetric compensation.

- Pre compensation: To compensate for dispersion, the DCF is mounted behind the SMF in the pre dispersion compensation scheme.
- Post compensation: DCF is mounted after the SMF in a post compensation system to compensate for the positive dispersion coefficient of SMF.
- Symmetric compensation: The symmetrical- compensation uses combination of both post and pre compensation at the same time. To compensate for dispersion, DCF is mounted both before and after the SMF.

In our Analysis our focus will be on comparing performance of a DWDM system with Pre and post compensation schemes applied to it when DWDM is RZ, MDRZ, NRZ encode on input side.

Binary 1 is characterised by positive high voltage and do not revert to 0 in NRZ line coding, while binary 0 signifies zero voltage. After the half bit duration of RZ line coding, the pulse that reflects the 'binary signal' returns to zero or ground potential. A logic 1's RZ signal will always start and stop at zero. A logic 1's NRZ signal transmission may or may not begin and end at zero.

In Fig. 1. For MDRZ, initially using a delay subtract circuit NRZ do binary signal is generated that drive a Mach Zehnder Modulator. After which it is concatenated with a second modulator powered by a sinusoidal electrical pulse which has a frequency of 40 Giga Hz. An XOR Gate whose feedback path is delayed was used in this duo binary precoder.

In this article, we investigated the efficiency of Post and Pre Dispersion Compensation Techniques in a DWDM networks using various encoding formats. SMF exhibits less dispersion, we preferred it over multi-mode fibre in our study.

SMF has the lowest loss at 1550 nm, but almost zero dispersion at 1310 nm. Optical amplifiers should be used in the transmission link in order to receive appropriate power signals at the receiver side.

FBG is a dispersion compensation system that is one of the most advanced and widely used. A fragment of optical fibre with intermittent variations in refractive index along the fibre axis is known as an FBG. The stage grinding is utilized as an impeding channel, mirroring the frequency that meets the Bragg condition and permitting different frequencies to pass. The reflected frequency changes with grinding period. Thus, FBG is extremely basic and ease channel for frequency determination that improves the quality and decreases the expenses in optical organizations [8].

## 2. System Design

In Opti-system (17), a 32-channel DWDM system with DCF and FBG as dispersion correction techniques is planned and simulated:

1. Different encoding scheme, such as NRZ, MDRZ, and RZ, are used to design transmitters.

2. Optical propagation span layouts vary between dispersion compensation systems.
3. System with FBG and dispersion compensation schemes.
4. The receiver.

Figure 2, employed a pseudo-random-bit-sequence generator in conjunction with an NRZ pulse generator, and the output is fed to one input of the Mach Zender Modulator, while a cw laser is fed to the other input of the Mach Zender Modulator. We set the frequency of the cw laser to 1550 nm, and the output of the Mach Zender Modulator is fed to an ideal MUX.

**Table 1:** Simulation Parameters

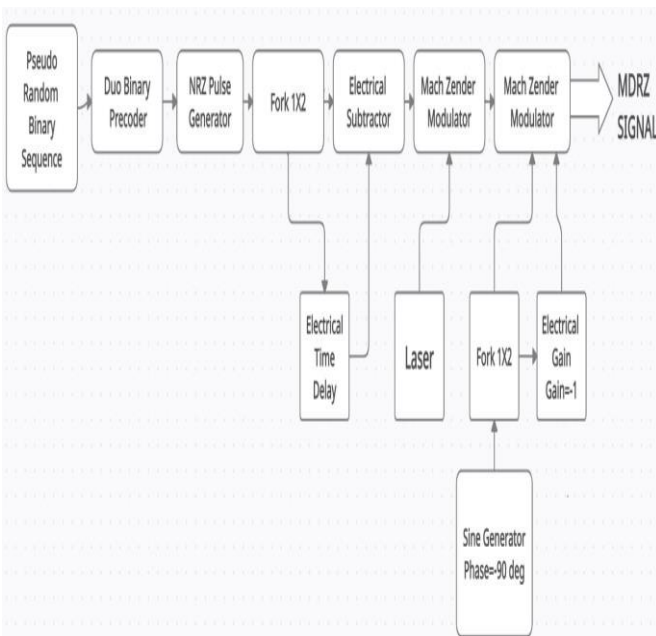
S.No	Parameter	Value	Unit
1.	PIN Responsivity	1	A/W
2.	Central Frequency	1500	nm
3.	Bit Rate	40	Gbps
4.	Distance	60*N	km
5.	Sequence Length	128	-
6.	Dark Current	0.1	nA
7.	Samples Rate	64	-
8.	LPF Cut-off Frequency	0.8*Bit Rate	-
9.	Channel Spacing	100	Hz

**Table 2:** Optical Fibre Parameters

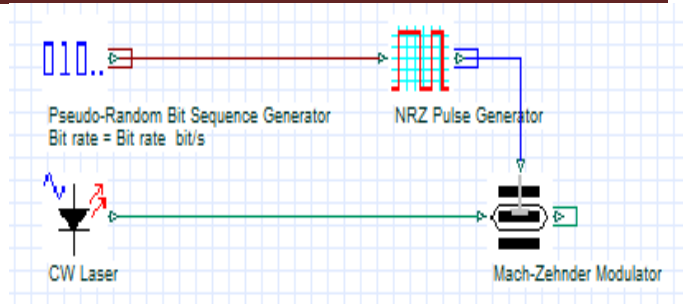
Property	SMF	DCF	Unit
Attenuation	0.2	0.5	dB/km
Dispersion	17	-85	ps/km-nm
Dispersion Slope	0.08	-0.4	ps/km-nm <sup>2</sup>
Effective core area	80	30	m <sup>2</sup>
Nonlinear refractive index	2.6	2.6	-

Figure 3, shows a pseudo random bit sequence generator in conjunction with a RZ pulse generator, and the output is fed to one input of a Mach Zender Modulator, and a CW laser is fed to the other input of the Mach Zender Modulator. We set the frequency of the cw laser to 1550 nm, and the output of the Mach Zender Modulator is fed to an ideal MUX.

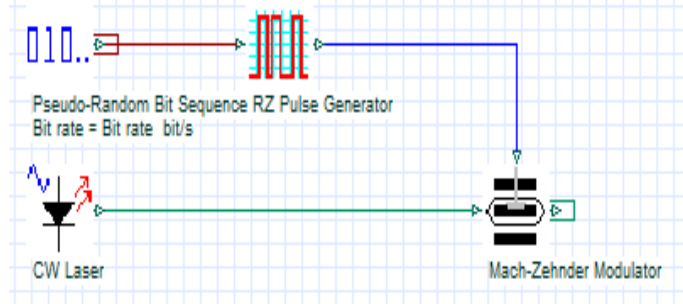
SMF receives the output of an optimal MUX, which is a multiplexed optical signal. To of the detrimental effects of dispersion on the relation, a dispersion compensating fibre (DCF) is used. [5].



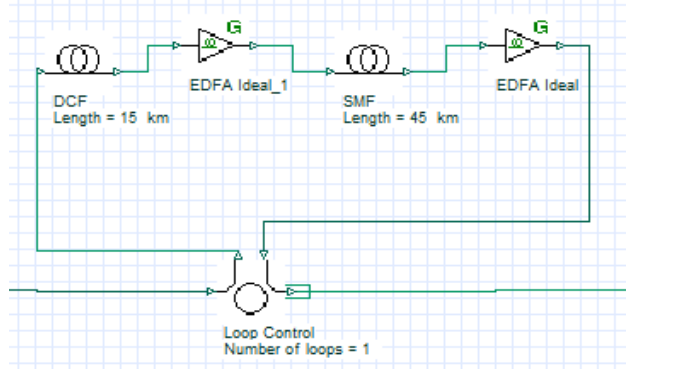
**Fig. 1:** MDRZ Encoder



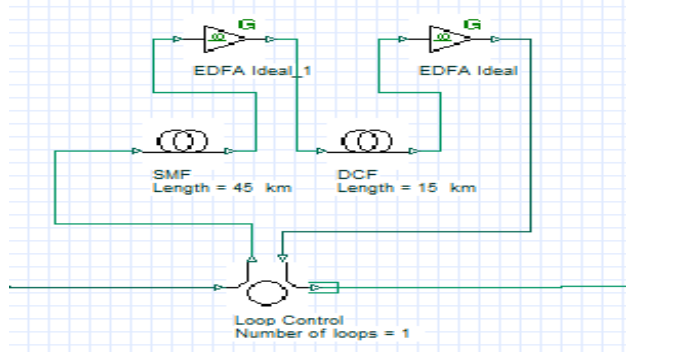
**Fig. 2:** NRZ Encoder



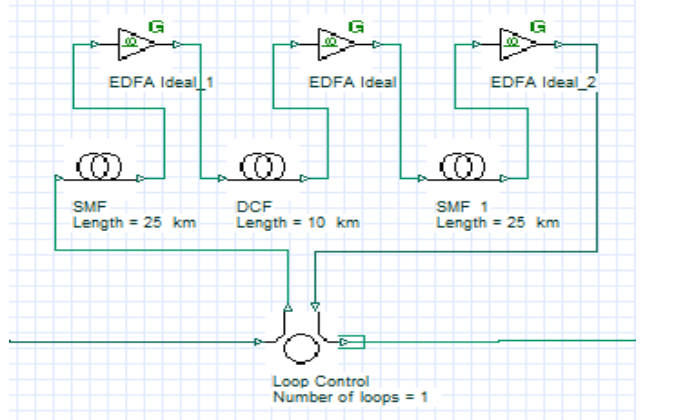
**Fig. 3:** RZ Encoder



**Fig. 4:** Pre Dispersion Compensation scheme



**Fig. 5:** Post Dispersion Compensation scheme



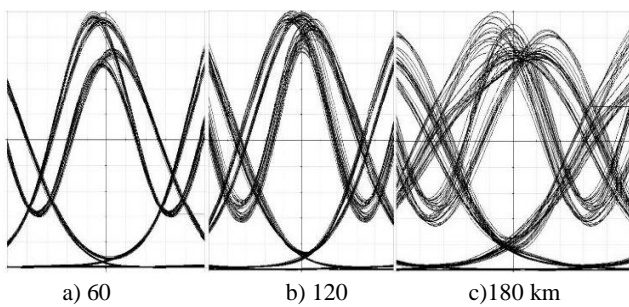
**Fig. 6:** Symmetrical Dispersion Compensation scheme

From figure 4 to figure 6 illustrates pre, post, symmetrical Dispersion Compensation Scheme Block diagram in opti-system. By using combination of EDFA, SMF, DCF to achieve these configurations.

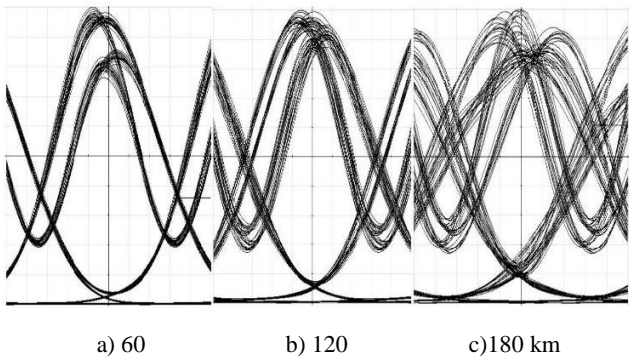
From figure 7 figure 12, all shows eye diagram for pre, post dispersion compensation without FBG we can see pre dispersion compensation shows widest eye opening in all the case so it shows best results .As The greater the eye opening, better are the results.

**Table 3:** MIN BER (Log10) and MAX Q Factor for transmission length In NRZ, MDRZ and RZ encoded DWDM network (Pre, Post, Pre+FBG, Post+FBG)

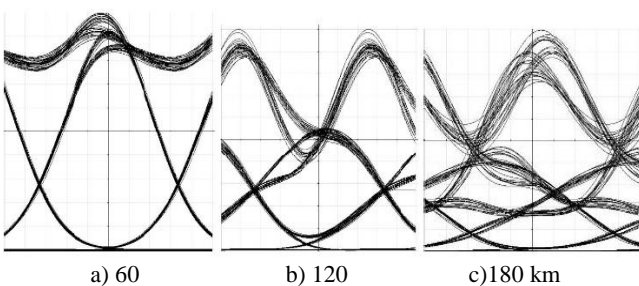
MAXIMUM Q FACTOR												
Length Km	MDRZ				RZ				NRZ			
	Pre	Pre +FBG	Post	Post+FBG	pre	pre + fbg	post	post + fbg	pre	pre + f bg	post	post + fbg
60	14.21	14.96	14.56	14.47	34.28	36.03	31.23	31.37	9.92	10.05	8.04	7.92
120	10.40	10.69	10.57	10.95	9.17	9.43	7.65	8.55	5.50	5.44	4.56	4.76
180	7.65	8.10	6.51	6.56	1.53	1.40	1.75	4.02	4.23	4.44	4.69	4.76
MINIMUM BER												
Length Km	MDRZ				RZ				NRZ			
	pre	pre + f bg	post	post + fbg	pre	pre + f bg	post	post + fbg	pre	pre + f bg	post	post + fbg
60	-45.38	-50.21	-47.59	-47.05	-257.17	-283.77	-215.62	-213.72	-22.90	-23.46	-15.44	-15.05
120	-25.02	-26.37	-27.57	-25.82	-19.62	-20.69	-14.01	-17.21	-7.78	-7.64	-5.87	-6.06
180	-15.57	-13.98	-10.43	-10.58	-1.30	-1.20	-4.54	-1.58	-4.97	-5.37	-5.63	-6.01



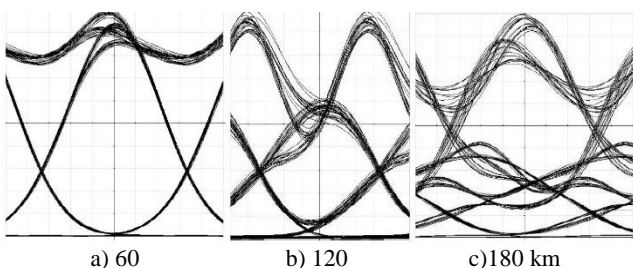
**Fig.7:** Pre MDRZ encoded DWDM



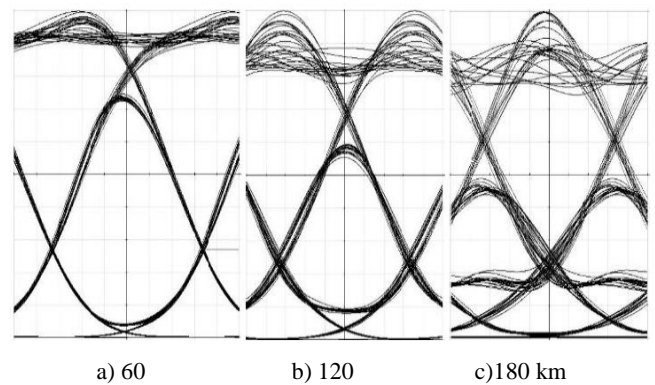
**Fig. 8:** Post MDRZ encoded DWDM



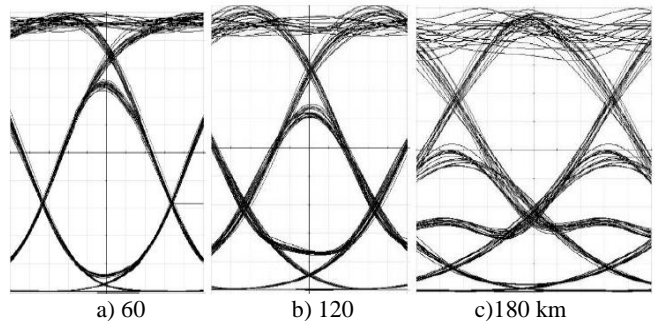
**Fig.9:** Pre RZ encoded DWDM



**Fig.10:** Post RZ encoded DWDM

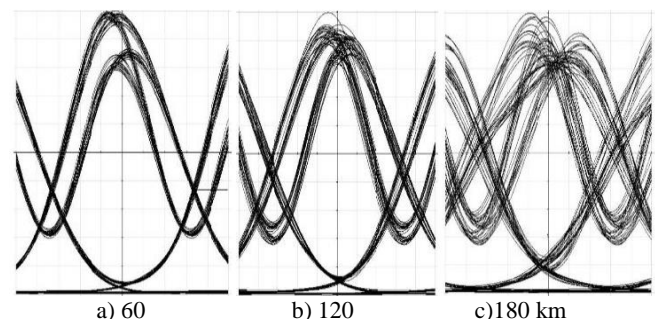


**Fig.11:** Pre NRZ encoded DWDM



**Fig.12:** Post NRZ encoded DWDM

Since the pre dispersion compensation system produces the best performance, we will attempt to develop it further by combining it with FBG.



**Fig.13:** Pre + FBG MDRZ encoded DWDM

From figure13 to figure 15 that eye diagrams are more specified when FBG is used in conjunction with Pre compensation schemes and is RZ encoded. Also, from Table 3, when use a mix of FBG and dispersion correction systems, the magnitude of Q-FACTOR is higher in most situations,

and the bit error rate is lower. Using Table 3, plotted a graph between Propagation length and Qfactor in figure16.

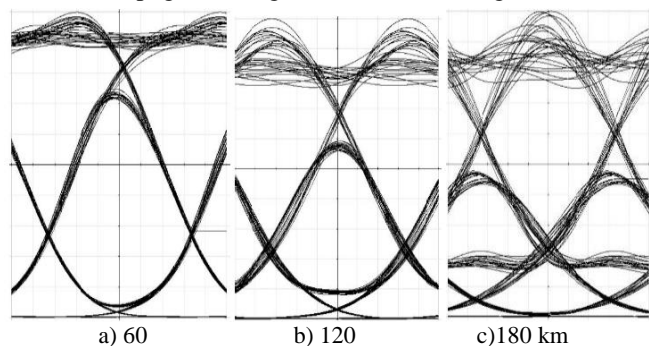


Fig.14: Pre + FBG NRZ encoded DWDM

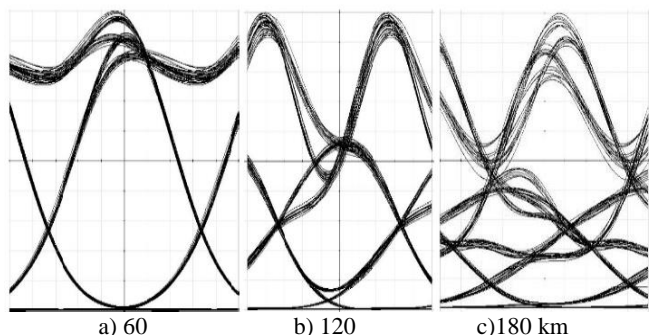


Fig.15: Pre+FBG RZ encoded DWDM

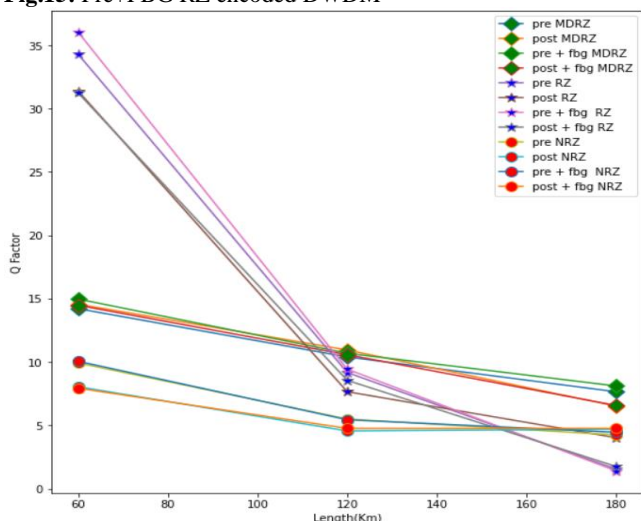


Fig.16: Q-Factor Vs Transmission length with Pre and Post Compensation

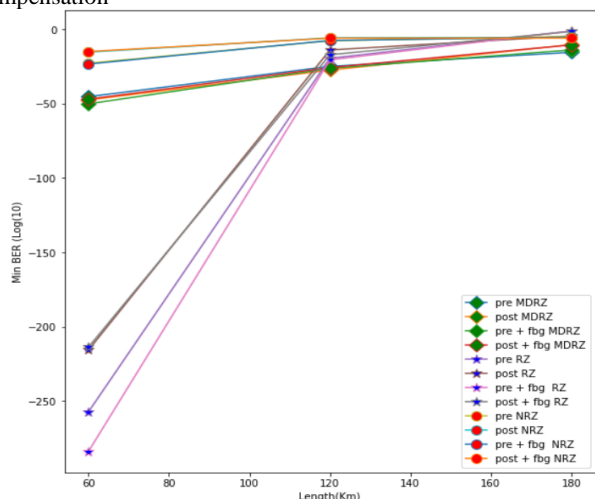


Fig.17: MIN BER Vs Transmission length with Pre and Post Compensation

Using Table 3 plot a graph between Propagation length and MIN BER in figure 17. From figure 16 and figure 17 we can see that BER is minimum in case of combination of PRE and FBG with RZ Encoding at 60 Km. Similarly Q factor is Maximum in case of combination of PRE and FBG with RZ Encoding at 60 Km. Most stable results are seen when the system is MDRZ encoded.

**4. Conclusions**

In this analysis find out that between Pre and Post compensation schemes in a 32 channel NRZ, MDRZ, NRZ encoded DWDM System the PRE dispersion compensation gives satisfactory result in most of the cases but the most effective results were seen between pre and post when we use combination PRE dispersion compensation with FBG it gives best results. At 60 Km RZ encoded gives best results but at 60,120,180 Km MDRZ shows most stable and constant results. It was found that when by using blend of PRE, POST dispersion compensation with FBG it gives better outcome when contrasted with utilizing just PRE, POST dispersion compensation.

**References**

- [1] Advanced Modulation Formats. <https://optiwave.com/resources/applications-resources/optical-system-advanced-modulation-formats/#:~:text=The%20MDRZ%20was%20generated%20by,the%20frequency%20of%2040%20GHz.>
- [2] HS Karanbir Singh. Analysis of Pre-, Post-, and Symmetrical Dispersion Compensation Techniques using DCF on 40 X 10 Gbps WDM-PON System. International Journal of Latest Technology in Engineering, Management & Applied Science, 4(6), 2017.
- [3] PM KK Panda. Simulation and performance analysis of dispersion. International Research Journal of Engineering and Technology (IRJET), 4(11), 2017.
- [4] HK Dixit. Performance study in dispersion compensation techniques with Duobinary format at different bit rates. 2nd International Conference on Power, Control and Embedded Systems, 2012.
- [5] Larry. Types of Optical Fiber Dispersion and Compensation Strategies. <https://community.fs.com/blog/types-of-optical-fiber-dispersion-and-compensation-strategies.html.4, 2020.>
- [6] M.Tosson, W. S.-D. (2015). Dispersion Compensation Techniques for DWDM Optical Networks. International Journal of Advanced Research in Computer and Communication Engineering, 4(8).
- [7] RZ vs NRZ | Comparison between RZ and NRZ Line Coding. (n.d.). Retrieved from <https://www.rfwireless-world.com/Terminology/Comparison-between-RZ-and-NRZ-Pulse-Shapes.html>
- [8] Y Chaba. Comparison of various dispersion compensation techniques at high bit rates. Elsevier Science Direct Optik 121, 2010, 813-817
- [9] SKaur, GK Gill. Performance Evaluation of 32 Channel DWDM System Using Dispersion Compensation Unit at Different Bit Rates., IRJET, 3(6), 2016.
- [10] V, S. Analysis of dispersion compensation techniques and fiber non-linear effects in dwdm optical networks. Chennai. <https://kumaraguruece.files.wordpress.com/2016/10/analysis-of-dispersion-compensation.pdf, 4, 2016>